

30V N-Ch Power MOSFET

Feature

- ◇ High Speed Power Switching, Logic Level
- ◇ Lead Free, Halogen Free

V_{DS}		30	V
$R_{DS(on),typ}$	$V_{GS}=10V$	30	mΩ
I_D (Silicon Limited)		5.5	A

Application

- ◇ Hard Switching and High Speed Circuit
- ◇ DC/DC in Telecoms and Industrial

Part Number	Package	Marking
HTO350N03	TSOP-6	1D

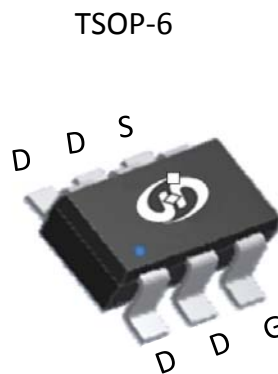

Absolute Maximum Ratings at $T_j=25^\circ\text{C}$ (unless otherwise specified)

Parameter	Symbol	Conditions	Value	Unit
Continuous Drain Current (Silicon Limited)	I_D	$T_A=25^\circ\text{C}$	5.5	A
		$T_A=70^\circ\text{C}$	3.6	
Drain to Source Voltage	V_{DS}	-	30	V
Gate to Source Voltage	V_{GS}	-	± 20	V
Pulsed Drain Current	I_{DM}	-	22	A
Power Dissipation	P_D	$T_A=25^\circ\text{C}$	1.25	W
Operating and Storage Temperature	T_J, T_{stg}	-	-55 to 150	$^\circ\text{C}$

Absolute Maximum Ratings

Parameter	Symbol	Max	Unit
Thermal Resistance Junction-Ambient	$R_{\theta JA}$	100	$^\circ\text{C/W}$

Electrical Characteristics at $T_J=25^{\circ}\text{C}$ (unless otherwise specified)
Static Characteristics

Parameter	Symbol	Conditions	Value			Unit
			min	typ	max	
Drain to Source Breakdown Voltage	$V_{(BR)DSS}$	$V_{GS}=0V, I_D=250\mu A$	30	-	-	V
Gate Threshold Voltage	$V_{GS(th)}$	$V_{GS}=V_{DS}, I_D=250\mu A$	1.0	1.50	3.0	
Zero Gate Voltage Drain Current	I_{DSS}	$V_{GS}=0V, V_{DS}=24V, T_J=25^{\circ}\text{C}$	-	-	1	μA
		$V_{GS}=0V, V_{DS}=20V, T_J=125^{\circ}\text{C}$	-	-	10	
Gate to Source Leakage Current	I_{GSS}	$V_{GS}=\pm 20V, V_{DS}=0V$	-	-	± 100	nA
Drain to Source on Resistance	$R_{DS(on)}$	$V_{GS}=10V, I_D=5.5A$	-	30	35	m Ω
		$V_{GS}=4.5V, I_D=4.5A$	-	40	50	
Transconductance	g_{fs}	$V_{DS}=5V, I_D=5.5A$	-	11	-	S

Dynamic Characteristics

Input Capacitance	C_{iss}	$V_{GS}=0V, V_{DS}=10V, f=1\text{MHz}$	-	323	-	pF
Output Capacitance	C_{oss}		-	75	-	
Reverse Transfer Capacitance	C_{rss}		-	53	-	
Total Gate Charge	$Q_g(10V)$	$V_{DD}=10V, I_D=5.5A, V_{GS}=10V$	-	7.1	-	nC
Gate to Source Charge	Q_{gs}		-	1.1	-	
Gate to Drain (Miller) Charge	Q_{gd}		-	2.2	-	
Turn on Delay Time	$t_{d(on)}$	$V_{DD}=15V, I_D=1A, V_{GS}=10V, R_G=6\Omega,$	-	8	-	ns
Rise time	t_r		-	12	-	
Turn off Delay Time	$t_{d(off)}$		-	28	-	
Fall Time	t_f		-	15	-	

Reverse Diode Characteristics

Diode Forward Voltage	V_{SD}	$V_{GS}=0V, I_F=2A$	-		1.2	V
-----------------------	----------	---------------------	---	--	-----	---

Fig 1. Typical Output Characteristics

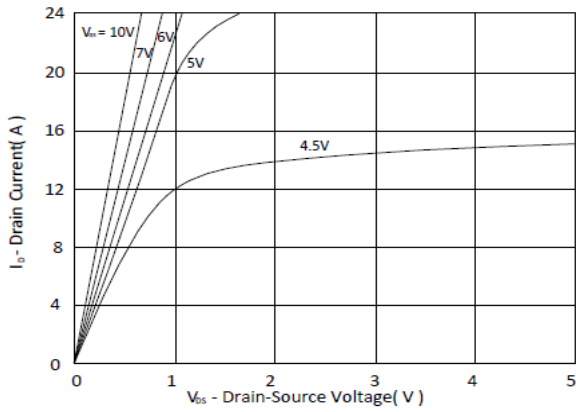

Figure 2. On-Resistance vs. Gate-Source Voltage

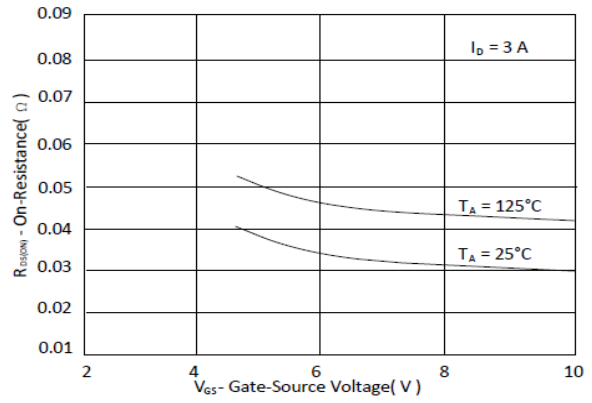

Figure 3. On-Resistance vs. Drain Current and Gate Voltage

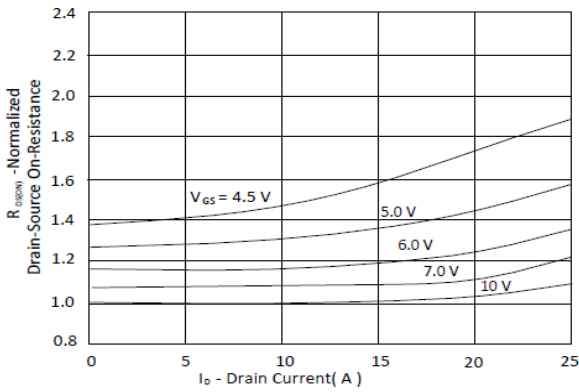

Figure 4. Normalized On-Resistance vs. Junction Temperature

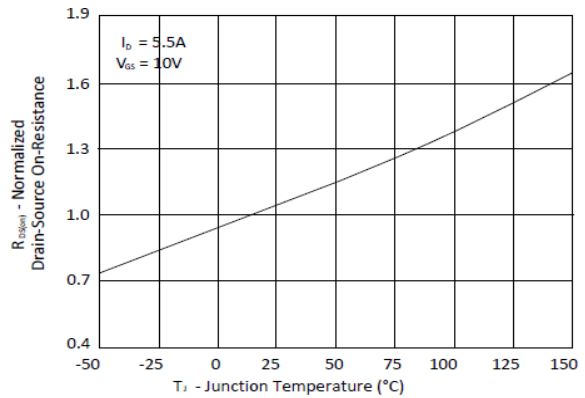

Figure 5. Typical Transfer Characteristics

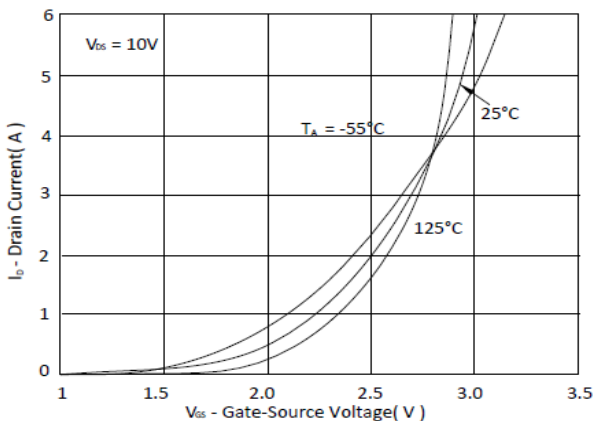

Figure 6. Typical Source-Drain Diode Forward Voltage

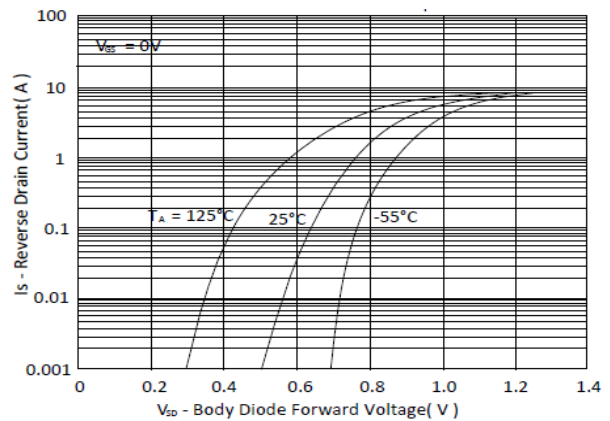

Figure 7. Typical Gate-Charge vs. Gate-to-Source Voltage

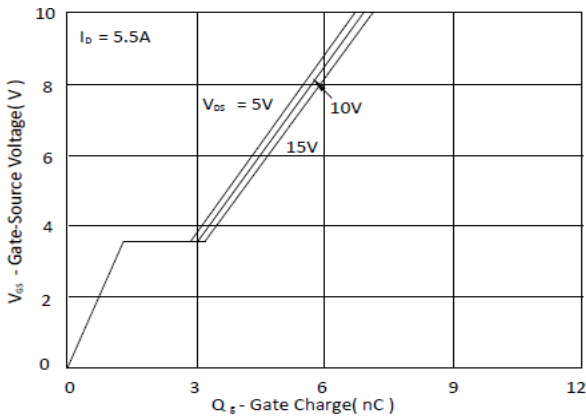

Figure 8. Typical Capacitance vs. Drain-to-Source Voltage

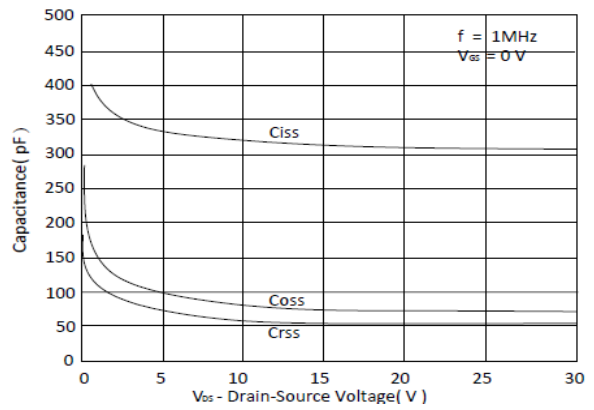

Figure 9. Maximum Safe Operating Area

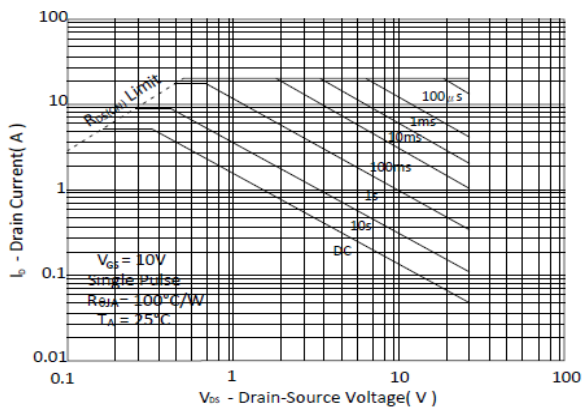

Figure 10. Single Pulse Maximum Power Dissipation

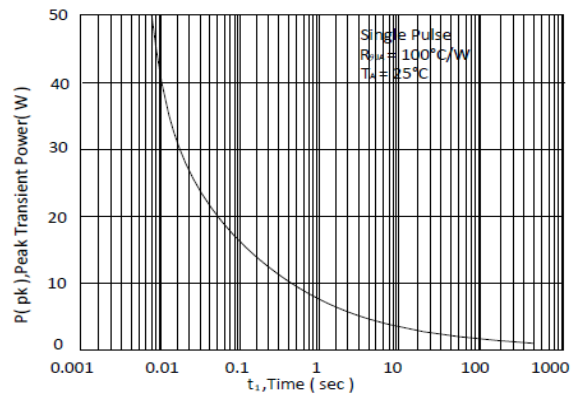
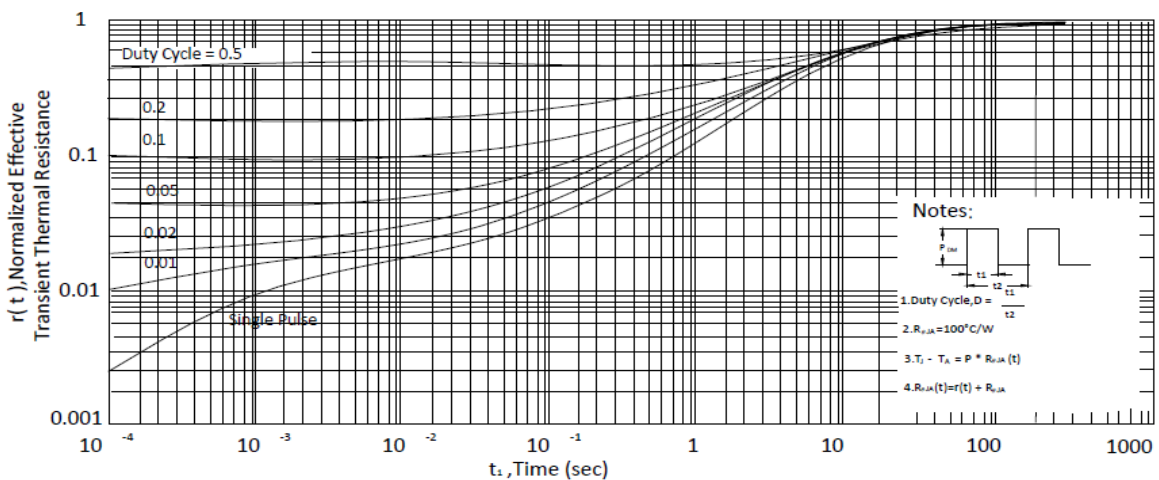
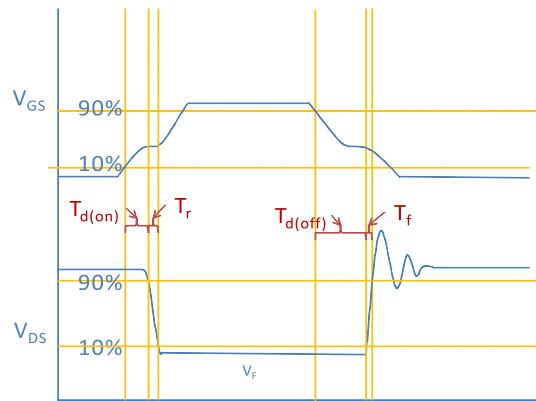
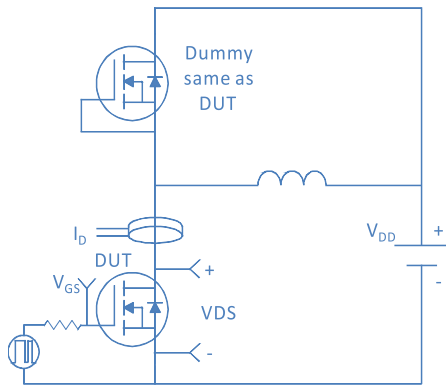

Figure 11. Normalized Maximum Transient Thermal Impedance, Junction-to-Ambient



Inductive switching Test



Gate Charge Test

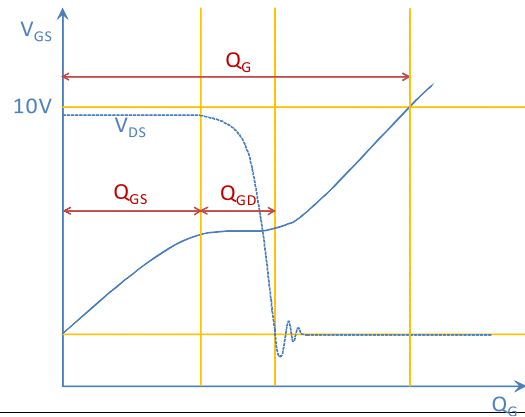
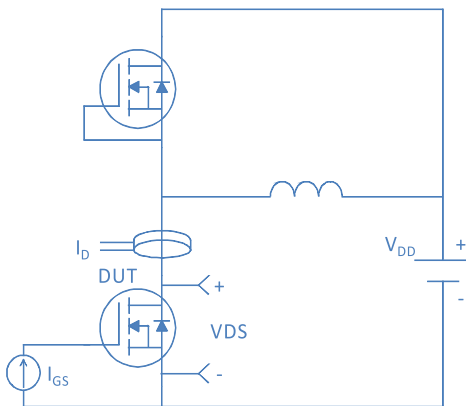

Uclamped Inductive Switching (UIS) Test

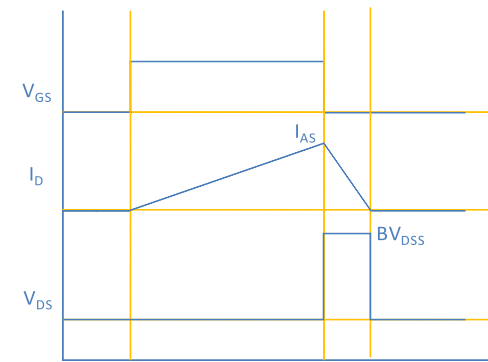
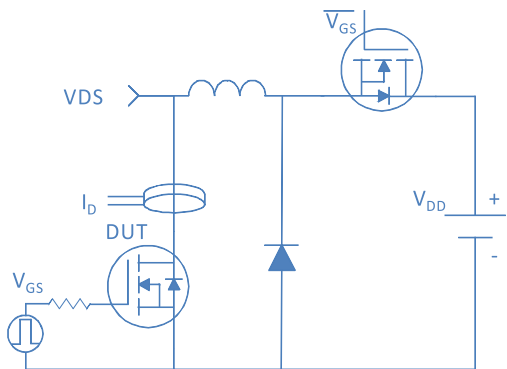

Diode Recovery Test

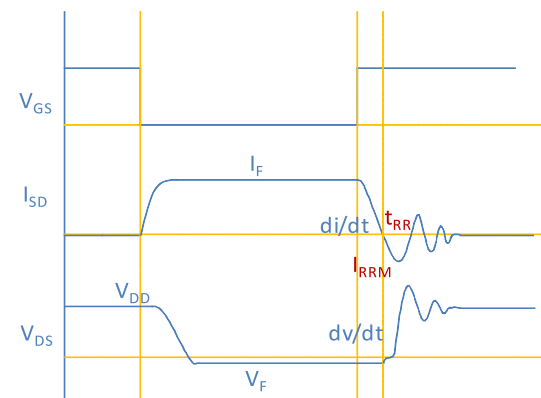
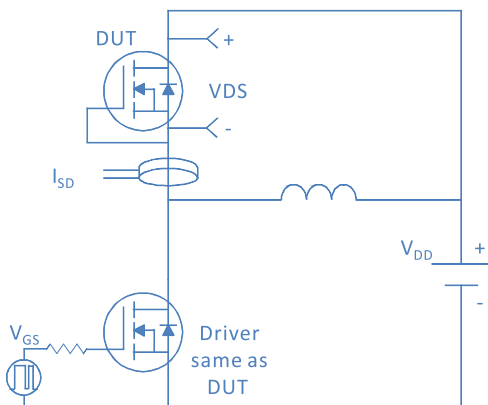

Package Outline

TSOP-6, 6leads

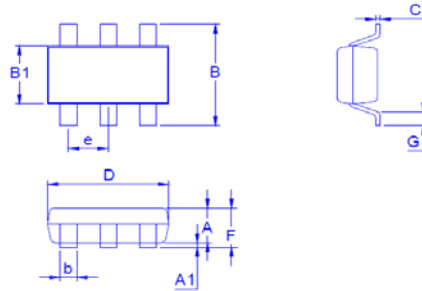

Dimension in mm

Dimension	A	A1	B	B1	b	C	D	e	F	G
Min.	0.85	0	2.50	1.50	0.30	0.08	2.70		0.85	0.20
Typ.	0.95		2.80	1.60	0.40		2.90	0.95		
Max.	1.25	0.15	3.10	1.70	0.50	0.20	3.10		1.40	0.60